

EQUIPMENT TOUCH

EQT3 DISPLAYS

The Equipment Touch EQT3 displays are rugged, industrial grade interfaces providing technicians with easy access to the equipment status, parameter values, schedules, alarms, and trends.

Designed for panel or wall mounting, they can load existing Equipment Touch files or new Custom Touch files built in ViewBuilder. The displays offer a contemporary design and include an IP65 rating on the front of the display, a wide temperature range and vibration resistance.

The user interface features are simple to operate for end users, but powerful enough to provide technicians a complete interface for maintaining equipment.

Key Features

- Available in four sizes (4.3", 7", 10.1", and 15")
- Rugged, industrial grade front display - suitable for mechanical rooms or board room mounting
- Rnet connection or Service Port (either Ethernet or USB) connection
- Fully customizable touchscreen for navigation and control with ViewBuilder
- Default system screens such as scheduling and trends
- Supports international languages
- Support for graphics and animations
- Screen captures can be saved to a USB flash drive
- Built-in PDF viewer

Benefits*

- Multi-level password protection for security
- Custom screens can show equipment graphic and operating status
- Ability to view/edit controller configuration for BAS integration (service port connection only)
- Ability to view and/or edit equipment configuration, schedules, trends, and alarms with pre-designed screens
- Trending with support for pinch zoom and swiping to move along time line
- Works great as a technician tool and as a user interface

**A custom equipment touch file is required*

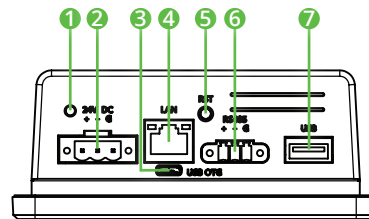

1. LED for Power
2. Power Terminal Block
3. USB OTG
4. RJ45/LAN
5. Reset Button
6. RS485 Rnet
7. USB Port

Equipment Touch 15.1" display

Part# EQT3-15



Equipment Touch 10.1" display

Part# EQT3-10



Equipment Touch 7" display

Part# EQT3-7



Equipment Touch 4.3" display

Part# EQT3-4



Specifications

	EQT3-4	EQT3-7	EQT3-10	EQT3-15
Power: 50-60 Hz, Class 2	24 Vdc, .375A	24 Vdc, .375A	24 Vdc, .417A	24 Vdc, .417A
Display: TFT	4.3" TFT (Widescreen)	7" TFT (Widescreen)	10.1" TFT (Widescreen)	15.6" TFT (Widescreen)
Resolution	480 x 272 pixels (128 ppi)	1024 x 600 pixels (170 ppi)	1280 x 800 pixels (149 ppi)	1366 x 768 pixels (252 ppi)
Brightness	400 cd/m (typ.)	320 cd/m (typ.)	350 cd/m (typ.)	400 nits
Contrast Ratio	1000:1 (typ.)	1000:1 (typ.)	800:1 (typ.)	500:1 (typ.)
Viewing Angle	-75~50(H); -75~75(V)	-75~70(H); -75~75(V)	-85~85(H); -85~85(V)	-85~85(H); -85~80(V)
Max Colors	16.7M (8-bit)	16.7M (8-bit)	16.7M (8-bit)	16.7M (8-bit)
Touchscreen	Projected Capacitive Multi-Touch (P-CAP) (same for all)			
Operating Conditions	-4°F to 122°F (-20°C to 50°C) 10% to 90% RH (non-condensing) Front IP65 water and dust proof (rear: IP20) Vibration tested to EN 60068-2-64			
Storage Temperature	-13°F to 158°F (-25°C to 70°C)			
Communication Ports	Comm Input Port: EIA-485 port for connection to the Rnet network (115kbps) USB Port: for upgrades, file copying, screen captures and connection to service port on controllers Micro USB On The Go (OTG) Port: for factory programming (firmware upgrades) LAN Port: RJ-45 Ethernet connection to service port on controllers			
System	OS: Android 11.0			
Processor	MT8365 Quad-core Cortex-A53 up to 2.0GHz			
System Memory	(4", 7", & 10" models) 3 GB LPDDR4 RAM (15" model) 4 GB LPDDR4 RAM			
Storage	32 GB onboard eMMC Flash storage			
Certifications	CE (Class B), FCC (Class B), CAN/CSA C22.2 No. 62368-1-14, ANSI/UL (62368-1, 2nd Ed), Vibration tested to EN 60068-2-6, IP65 rated (front) IP20 rated (rear)			

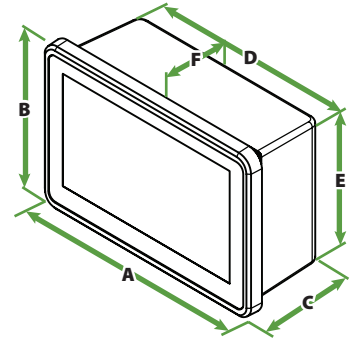

Wall Mounting Kits also available:
Parts: EQT3-7-MOUNT, EQT3-10-MOUNT

EQT3-4 Dimensions

- A:** 121 mm (4.76") **D:** 110 mm (4.33")
B: 82 mm (3.23") **E:** 74 mm (2.91")
C: 49 mm (1.93") **F:** 42 mm (1.65")

EQT3-7 Dimensions

- A:** 185 mm (7.28") **D:** 175 mm (6.89")
B: 128 mm (5.04") **E:** 118 mm (4.65")
C: 46 mm (1.81") **F:** 39 mm (1.52")

EQT3-10 Dimensions

- A:** 267 mm (10.5") **D:** 244 mm (9.61")
B: 182 mm (7.17") **E:** 159 mm (6.26")
C: 47 mm (1.85") **F:** 39 mm (1.52")

EQT3-15 Dimensions

- A:** 421 mm (16.57") **D:** 388.4 mm (15.29")
B: 260.5 mm (10.26") **E:** 195.5 mm (7.7")
C: 52.5 mm (2.07") **F:** 46.5 mm (1.83")

Sample Screenshots

