

# OPTICORE EQT3 DISPLAYS

The OptiCORE EQT3 displays are rugged, industrial grade interfaces providing technicians with easy access to the equipment status, parameter values, schedules, alarms, and trends.

Designed for panel or wall mounting, they can load existing Equipment Touch files or new Custom Touch files built in ViewBuilder. The displays offer a contemporary design and include an IP65 rating on the front of the display, a wide temperature range and vibration resistance.

The user interface features are simple to operate for end users, but powerful enough to provide technicians a complete interface for maintaining equipment.

## Key Features

- Fanless cooling system and ultra-low power consumption
- Front IP65 water and dust proof
- Access to virtually any data point in the controller
- Support for graphics and animations
- Schedule Interface – view and edit BACnet schedules
- Alarm Viewing – view the controller’s alarm history buffer
- Trending with support for pinch zoom and swiping to move along timeline
- Support for 13 languages
- Multi-level password protection
- PDF viewer
- Screen capture to USB flash drive
- Supports loading of .touch file stored on EQT3 displays or uploaded from controller

## Customize for any application with ViewBuilder

- WYSIWYG editor
- Simple and intuitive
- Library of interactive controls
- View file stored in controller
- 1 file supports multiple languages
- Create custom alarm text
- Assign passwords to screens
- Use conditional hide to allow one view file to work on similar equipment with varying features

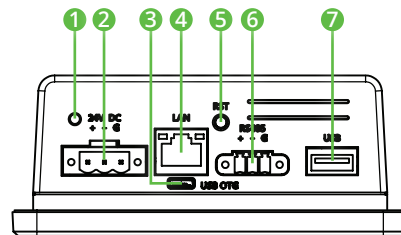

1. LED for Power
2. Power Terminal Block
3. USB OTG
4. RJ45/LAN
5. Reset Button
6. RS485
7. USB Port

## OptiCORE ET10 display

Part# EQT3-10



## OptiCORE ET7 display

Part# EQT3-7



## OptiCORE ET4 display

Part# EQT3-4



# Specifications

	EQT3-4	EQT3-7	EQT3-10
Power: 50-60 Hz, Class 2	24 Vdc, .375A	24 Vdc, .375A	24 Vdc, .417A
Display: TFT	4.3" TFT (Widescreen)	7" TFT (Widescreen)	10.1" TFT (Widescreen)
Resolution	480 x 272 pixels (128 ppi)	1024 x 600 pixels (170 ppi)	1280 x 800 pixels (149 ppi)
Brightness	400 cd/m (typ.)	320 cd/m (typ.)	350 cd/m (typ.)
Contrast Ratio	1000:1 (typ.)	1000:1 (typ.)	800:1 (typ.)
Viewing Angle	-75~50(H); -75~75(V)	-75~70(H); -75~75(V)	-85~85(H); -85~85(V)
Max Colors	16.7M (8-bit)	16.7M (8-bit)	16.7M (8-bit)
Touch	Projected Capacitive Multi-Touch (P-CAP) (same for all)		
Operating Conditions	-4°F to 122°F (-20°C to 50°C) 10% to 90% RH (non-condensing) Front IP65 water and dust proof (rear: IP20) Vibration tested to EN 60068-2-6		
Storage Temperature	-13°F to 158°F (-25°C to 70°C)		
Communication	3 ways to communicate from EQT3 to controller: Ethernet USB-A 2.0 Host Port EIA-485 Rnet Port USB OTG Port		
System	OS: Android 11.0 Processor MT8365 Quad-core Cortex-A53 up to 2.0GHz System Memory 3 GB LPDDR4 RAM Storage 32 GB onboard eMMC Flash storage		
Certifications	CE (Class B), FCC (Class B), CSA (IEC 62368-1), Vibration tested to EN 60068-2-6, IP65 rated (front) IP20 rated (rear)		

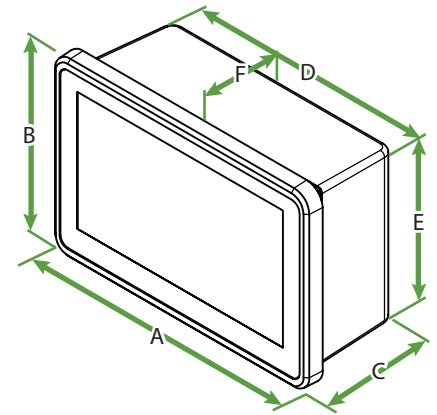

## EQT3-4 Dimensions

**A:** 121 mm (4.76")    **D:** 110 mm (4.33")  
**B:** 82 mm (3.23")    **E:** 74 mm (2.91")  
**C:** 49 mm (1.93")    **F:** 42 mm (1.65")

## EQT3-7 Dimensions

**A:** 185 mm (7.28")    **D:** 175 mm (6.89")  
**B:** 128 mm (5.04")    **E:** 118 mm (4.65")  
**C:** 46 mm (1.81")    **F:** 39 mm (1.52")

## EQT3-10 Dimensions

**A:** 267 mm (10.5")    **D:** 244 mm (9.61")  
**B:** 182 mm (7.17")    **E:** 159 mm (6.26")  
**C:** 47 mm (1.85")    **F:** 39 mm (1.52")

## Sample Screenshots

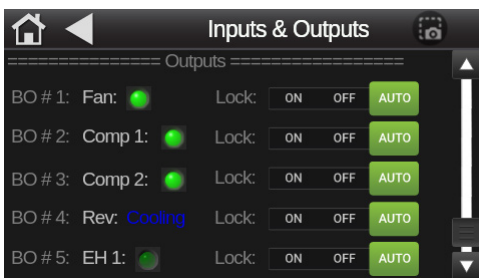
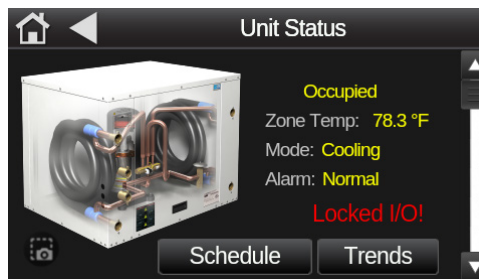

1025 Cobb Place Boulevard, Kennesaw, GA 30144  
 770-429-3060 | oemctrl.com

Rev. 08/23

All trademarks used herein are the property of their respective owners.

A Carrier Company  
 ©2023 Carrier. All Rights Reserved.